

EG800G Series QuecOpen **Reference Design**

LTE Standard Module Series

Version: 1.1

Date: 2024-12-09

Status: Released



At Quectel, our aim is to provide timely and comprehensive services to our customers. If you require any assistance, please contact our headquarters:

Quectel Wireless Solutions Co., Ltd.

Building 5, Shanghai Business Park Phase III (Area B), No.1016 Tianlin Road, Minhang District, Shanghai 200233, China

Tel: +86 21 5108 6236

Email: info@quectel.com

Or our local offices. For more information, please visit:

<http://www.quectel.com/support/sales.htm>.

For technical support, or to report documentation errors, please visit:

<http://www.quectel.com/support/technical.htm>.

Or email us at: support@quectel.com.

Legal Notices

We offer information as a service to you. The provided information is based on your requirements and we make every effort to ensure its quality. You agree that you are responsible for using independent analysis and evaluation in designing intended products, and we provide reference designs for illustrative purposes only. Before using any hardware, software or service guided by this document, please read this notice carefully. Even though we employ commercially reasonable efforts to provide the best possible experience, you hereby acknowledge and agree that this document and related services hereunder are provided to you on an “as available” basis. We may revise or restate this document from time to time at our sole discretion without any prior notice to you.

Use and Disclosure Restrictions

License Agreements

Documents and information provided by us shall be kept confidential, unless specific permission is granted. They shall not be accessed or used for any purpose except as expressly provided herein.

Copyright

Our and third-party products hereunder may contain copyrighted material. Such copyrighted material shall not be copied, reproduced, distributed, merged, published, translated, or modified without prior written consent. We and the third party have exclusive rights over copyrighted material. No license shall be granted or conveyed under any patents, copyrights, trademarks, or service mark rights. To avoid ambiguities, purchasing in any form cannot be deemed as granting a license other than the normal non-exclusive, royalty-free license to use the material. We reserve the right to take legal action for noncompliance with abovementioned requirements, unauthorized use, or other illegal or malicious use of the material.

Trademarks

Except as otherwise set forth herein, nothing in this document shall be construed as conferring any rights to use any trademark, trade name or name, abbreviation, or counterfeit product thereof owned by Quectel or any third party in advertising, publicity, or other aspects.

Third-Party Rights

This document may refer to hardware, software and/or documentation owned by one or more third parties (“third-party materials”). Use of such third-party materials shall be governed by all restrictions and obligations applicable thereto.

We make no warranty or representation, either express or implied, regarding the third-party materials, including but not limited to any implied or statutory, warranties of merchantability or fitness for a particular purpose, quiet enjoyment, system integration, information accuracy, and non-infringement of any third-party intellectual property rights with regard to the licensed technology or use thereof. Nothing herein constitutes a representation or warranty by us to either develop, enhance, modify, distribute, market, sell, offer for sale, or otherwise maintain production of any our products or any other hardware, software, device, tool, information, or product. We moreover disclaim any and all warranties arising from the course of dealing or usage of trade.

Privacy Policy

To implement module functionality, certain device data are uploaded to Quectel’s or third-party’s servers, including carriers, chipset suppliers or customer-designated servers. Quectel, strictly abiding by the relevant laws and regulations, shall retain, use, disclose or otherwise process relevant data for the purpose of performing the service only or as permitted by applicable laws. Before data interaction with third parties, please be informed of their privacy and data security policy.

Disclaimer

- a) We acknowledge no liability for any injury or damage arising from the reliance upon the information.
- b) We shall bear no liability resulting from any inaccuracies or omissions, or from the use of the information contained herein.
- c) While we have made every effort to ensure that the functions and features under development are free from errors, it is possible that they could contain errors, inaccuracies, and omissions. Unless otherwise provided by valid agreement, we make no warranties of any kind, either implied or express, and exclude all liability for any loss or damage suffered in connection with the use of features and functions under development, to the maximum extent permitted by law, regardless of whether such loss or damage may have been foreseeable.
- d) We are not responsible for the accessibility, safety, accuracy, availability, legality, or completeness of information, advertising, commercial offers, products, services, and materials on third-party websites and third-party resources.

Copyright © Quectel Wireless Solutions Co., Ltd. 2024. All rights reserved.

About the Document

Revision History

Version	Date	Author	Description
-	2023-08-18	Phoebe FU/ Eric MO	Creation of the document
1.0	2023-11-16	Phoebe FU/ Eric MO	First official release
1.1	2024-12-09	Phoebe FU/ Eric MO	<ol style="list-style-type: none"> 1. Updated pins 5, 6, 26 and 106 from RESERVED to GPIO1, GPIO2, PCM_MCLK and CAM_VDDIO respectively. 2. Connected CODEC_3V3_EN to GPIO12 of MCU (Sheets 1 and 4). 3. Added flash power supply design (Sheets 2 and 5). 4. Updated the power supply of camera from VDD_EXT to CAM_VDDIO (Sheets 2 and 13). 5. Added 33 pF capacitors on PCM_DOUT, PCM_DIN, PCM_SYNC, PCM_CLK and PCM_MCLK and added a note on PCM interface (Sheet 3). 6. Updated SD card power supply design (Sheet 5). 7. Updated reference circuit for antenna interfaces and added relevant notes (Sheet 6). 8. Deleted capacitors on PCM_SYNC, PCM_DIN and PCM_DOUT traces; Updated the capacitance on SPK_N/_P traces to 220 nF (Sheet 9). 9. Updated the power supply of external flash interface from VDD_EXT to VDD_1V8 (Sheet 15). 10. Updated DC_5V of NET_STATUS power supply to VBAT (Sheet 16).

Contents

About the Document	3
Contents	4
1 Reference Design	5
1.1. Introduction	5
1.2. Special Mark	5
1.3. Schematics	5

1 Reference Design

1.1. Introduction

This document provides the reference design for Quectel EG800G series module in QuecOpen® solution, including block diagrams of module interfaces, power supply, antenna, USIM, UART, audio codec, LCM, camera, SD card interfaces.

1.2. Special Mark

Table 1: Special Mark

Mark	Definition
[...]	Brackets ([...]) used after a pin enclosing a range of numbers indicate all pins of the same type. For example, SDIO_DATA [0:3] refers to all four SDIO_DATA pins, SDIO_DATA0, SDIO_DATA1, SDIO_DATA2 and SDIO_DATA3.

1.3. Schematics

The schematics illustrated in the following pages are provided for your reference only.

NOTE

It is required to confirm the applicability and price from the supplier about the IC involved in the reference design.

Block Diagram

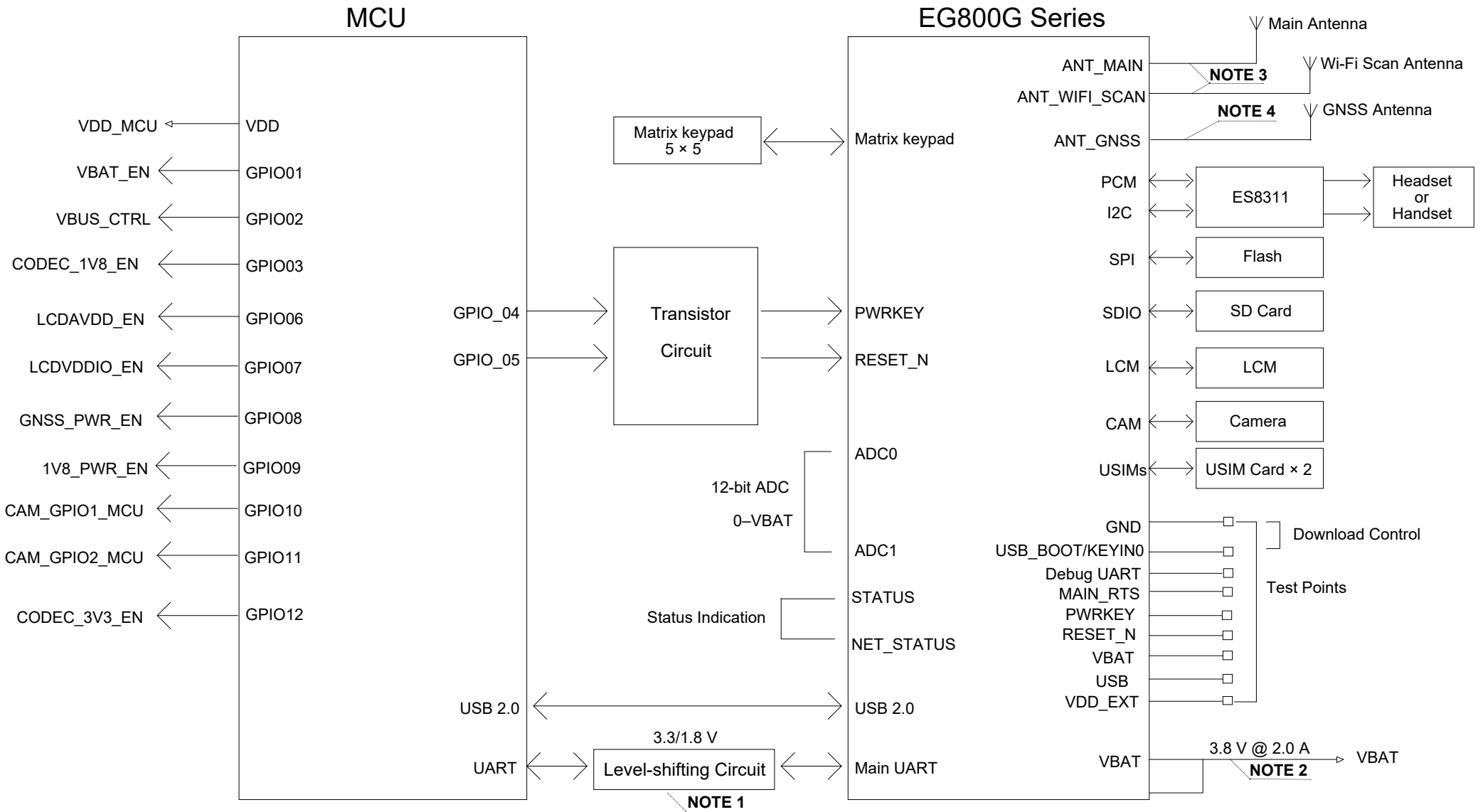

NOTE:

- A transistor circuit or a voltage-level translator TXS0104EPWR provided by Texas Instruments is recommended.
- The power supply for the module should be capable of supplying a minimum current of 2.0 A.
- EG800G-CN supports Wi-Fi scan function, which shares the same antenna interface with main antenna. The two functions cannot be used simultaneously.
EG800G-EU/-LA provides a dedicated Wi-Fi scan antenna interface (ANT_WIFI_SCAN). Wi-Fi scan supports receiving only.
- EG800G-CN supports GNSS function. EG800G-EU/-LA does not support GNSS function.

Power System Block Diagram

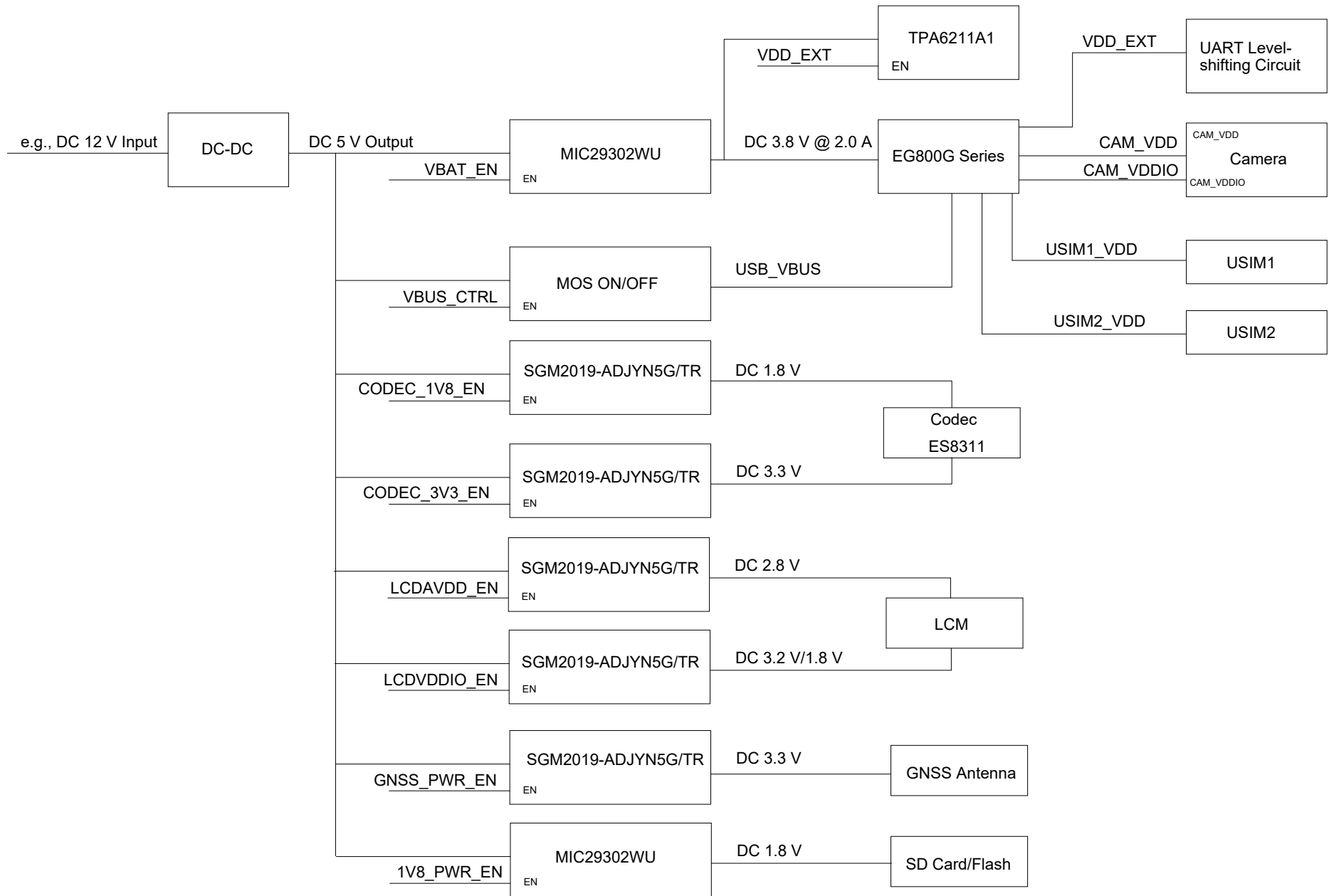

NOTE:

1. The power supply for the module should be capable of supplying a minimum current of 2.0 A.
2. EG800G-CN supports GNSS function. EG800G-EU/-LA does not support GNSS function.

Quectel Wireless Solutions			
PROJECT	EG800G Series QuecOpen	VER	1.1
DRAWN BY	Phoebe FUJIE MO	CHECKED BY	Anita HUANG
DATE	2024-12-09	SHEET	2 OF 19

Module Interfaces

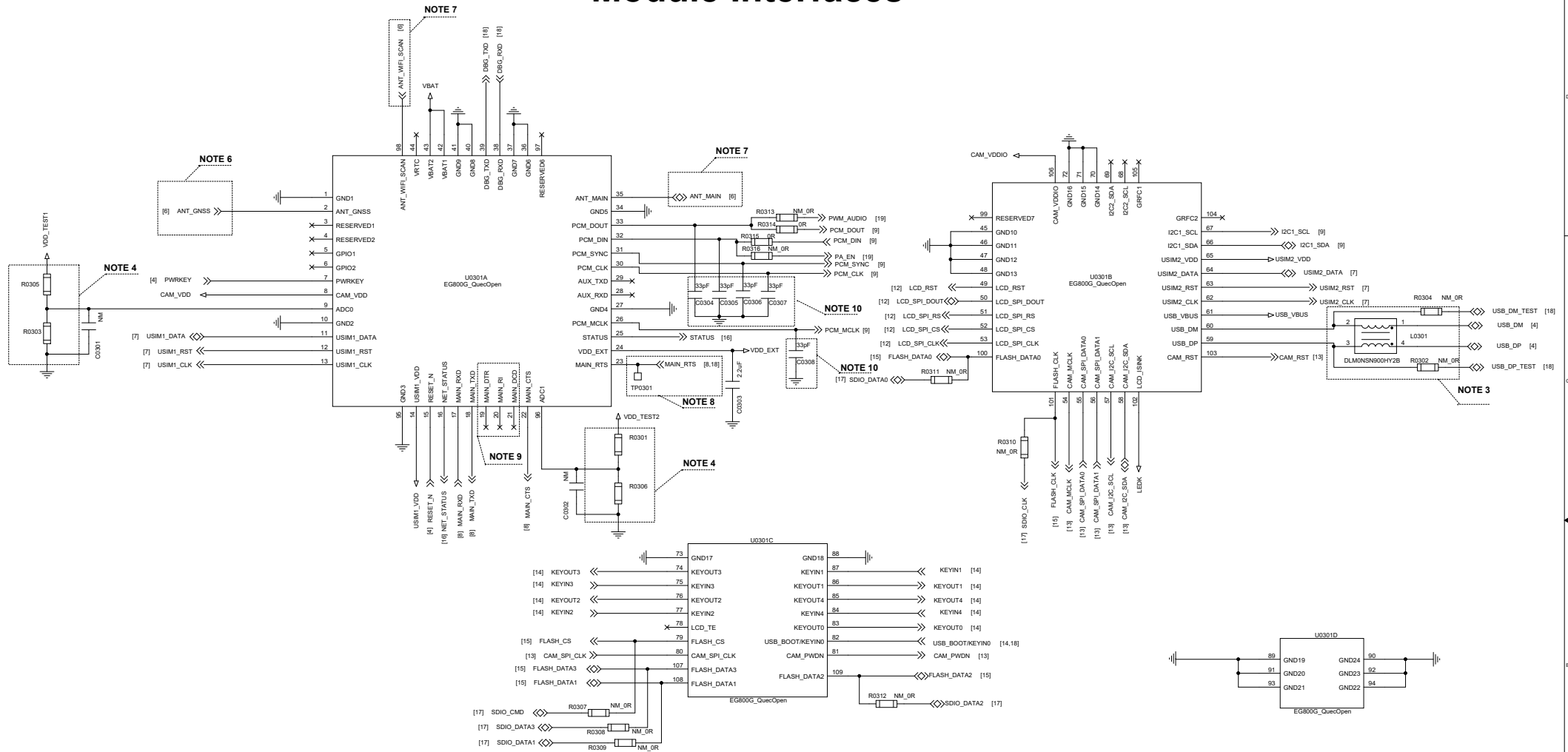

NOTE:

- Keep unused and RESERVED pins open, and all GND pins should be connected to the ground.
- Ensure there is a complete reference ground plane below the module, and the ground plane is as close to the module layer as possible. It is recommended to design at least 4-layers.
- A common mode choke L0301 is recommended to be added in series between the module and your MCU to suppress EMI. Meanwhile, reserve the test points for upgrading the firmware over USB interface and minimize the extra stubs of the trace. L0301 and the two resistors R0302 and R0304 should be placed close to the module to ensure the integrity of USB signal.
- Considering the difference of ADC voltage range among Quectel modules, when it is necessary to use ADC pins, it is strongly recommended to reserve the voltage divider circuit for better compatibility with other Quectel modules. The resistance of the divider must be less than 100 kΩ, otherwise the measurement accuracy of the ADC will be significantly reduced. When the divider circuit is not used, the ADC pins require 1 kΩ resistors in series.
- If the forced download function is not used, USB_BOOT/KEYIN0 cannot be pulled down to low level or pulled up to high level before the module is successfully turned on. KEYIN1, KEYIN2 cannot be pulled down to low level before the module is successfully turned on.
- EG800G-CN supports GNSS function. EG800G-EU/-LA does not support GNSS function.
- EG800G-CN supports Wi-Fi scan function, which shares the same antenna interface with main antenna. The two functions cannot be used simultaneously. EG800G-EU/-LA provides a dedicated Wi-Fi scan antenna interface (ANT_WIFI_SCAN). Wi-Fi scan supports receiving only.
- Test points must be reserved for MAIN_RTS, DBG_TXD/RXD, USB_DP/DM and USB_VBUS. It is recommended to reserve test points for USB_BOOT/KEYIN0, VDD_EXT, VBAT and PWRKEY. If RESET_N is unused, it is recommended to reserve a test point.
- MAIN_DTR, MAIN_RI and MAIN_DCD do not have the functions described by the pin names and their default functions are GPIOs.
- If PCM_MCLK is used for codec, RC filter circuit should be reserved for PCM interface (pins 26, 30-33) of the module. The termination resistance and filter capacitance should be confirmed according to the actual situation.

MCU Interfaces

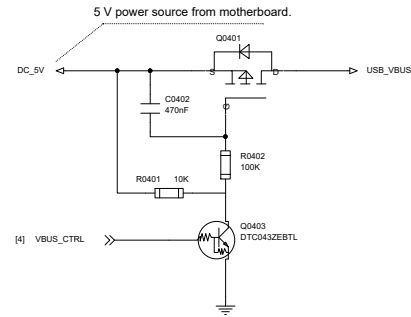
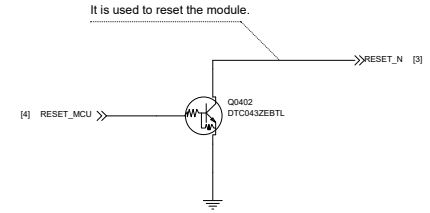
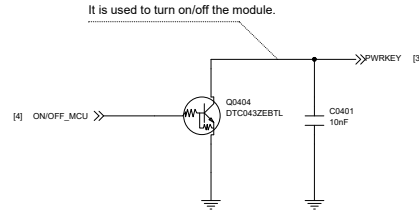
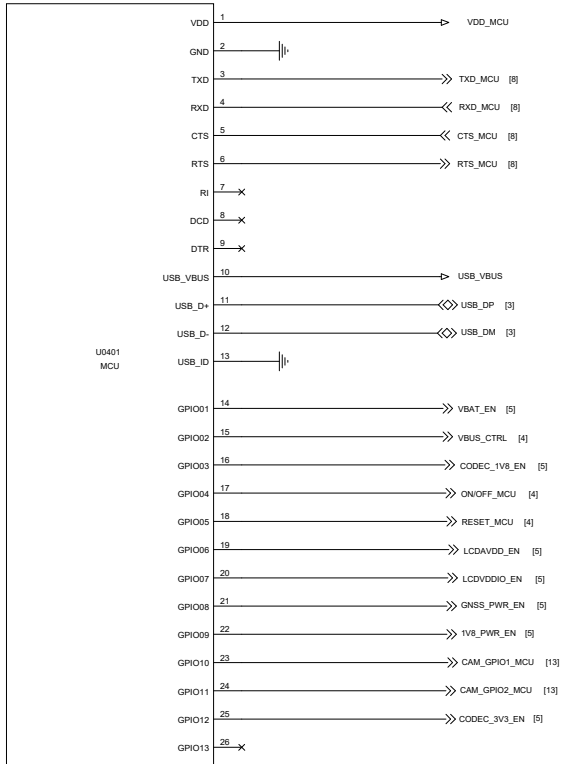

NOTE:

- U0401 represents your MCU. The power domain of GPIO interfaces of the module is 1.8 V. If the GPIO interfaces of U0401 share the same power domain, the related level-shifting circuit is not needed.
- The USB 2.0 interface of the module only serves as a slave device and supports full-speed and high-speed modes. To communicate with the USB interface, MCU needs to support USB host mode or OTG function.
The USB_VBUS pin of the module should be powered by an external power system for USB detection, and VBUS_CTRL is used to turn on/off the USB_VBUS power supply.
- It is recommended to select the default low-level GPIO pins of MCU as the control pins for PWRKEY and RESET_N of the module. Ensure that the maximum load capacitance of pins PWRKEY and RESET_N does not exceed 10 nF.

Power Supply Design

DC-DC Application

When the input voltage is above 7.0 V, use a DC-DC converter to convert the high input voltage into 5.0 V, and then use LDOs to convert it to 3.8 V, 3.3 V, 3.2 V, 2.8 V, and 1.8 V to power the module, audio PA, SD card, flash, codec, GNSS antenna and LCM.

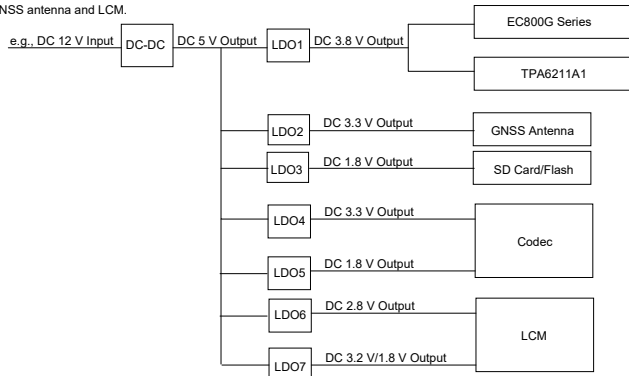

VBAT Design

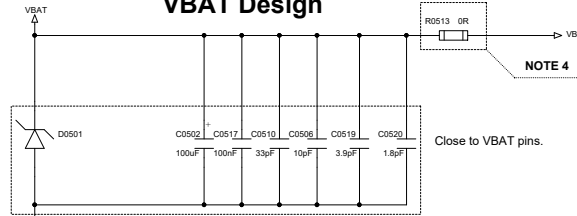

- NOTE:**
- The power supply for the module should be capable of supplying a minimum current of 2.0 A.
 - The width of VBAT trace should be at least 2 mm.
 - The recommended operating voltage of VBAT ranges from 3.3 V to 4.3 V. The typical operating voltage of VBAT is 3.8 V.
 - It is recommended to reserve a 0 Ω resistor (minimum package size: 0603) for future debugging. The resistor should be placed close to VBAT pins.

LDO Application

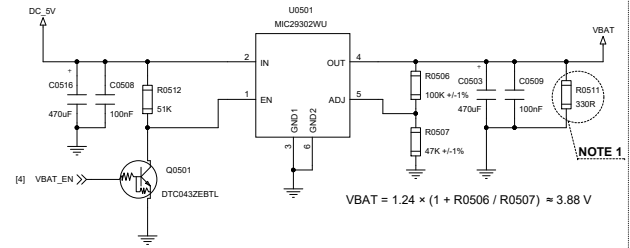

- NOTE:**
- The recommended load current is greater than 10 mA.
 - When the input voltage is below 7.0 V, use an LDO to convert the input voltage to 3.8 V.

GNSS Antenna Power Supply

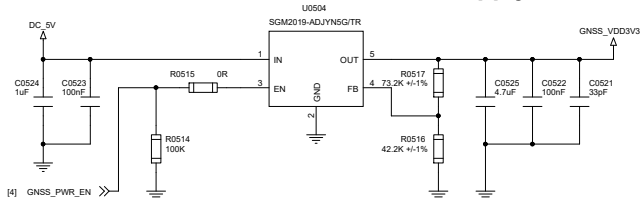

- NOTE:**
EG800G-CN supports GNSS function. EG800G-EU/LA does not support GNSS function.

$$\text{GNSS_VDD3V3} = 1.207 \times (1 + R0517 / R0516) \approx 3.3 \text{ V}$$

Codec Power Supply

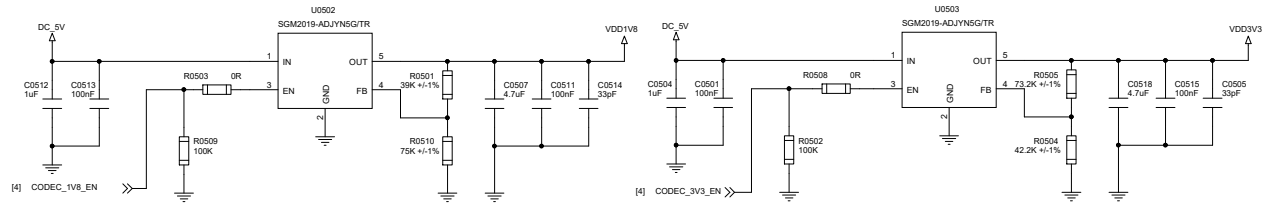

- NOTE:**
- CODEC_3V3_EN and CODEC_1V8_EN are used to turn on/off of VDD3V3 and VDD1V8 respectively.
 - To ensure proper functioning of the audio codec, adhere to the following power-up/down sequences:
Power-up sequence: power on VDD1V8 first, followed by VDD3V3.
Power-down sequence: power off VDD3V3 first, followed by VDD1V8.

$$\text{VDD1V8} = 1.207 \times (1 + R0501 / R0510) \approx 1.8 \text{ V}$$

$$\text{VDD3V3} = 1.207 \times (1 + R0505 / R0504) \approx 3.3 \text{ V}$$

SD Card/Flash Power Supply

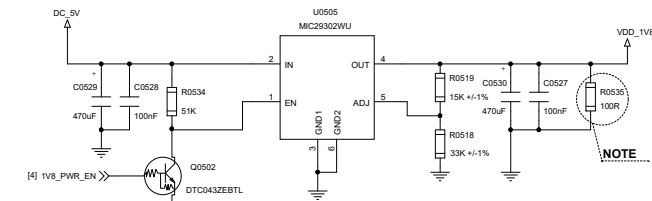

- NOTE:**
The recommended load current is greater than 10 mA.

$$\text{VDD_1V8} = 1.24 \times (1 + R0519 / R0518) \approx 1.8 \text{ V}$$

LCM Digital Power Supply

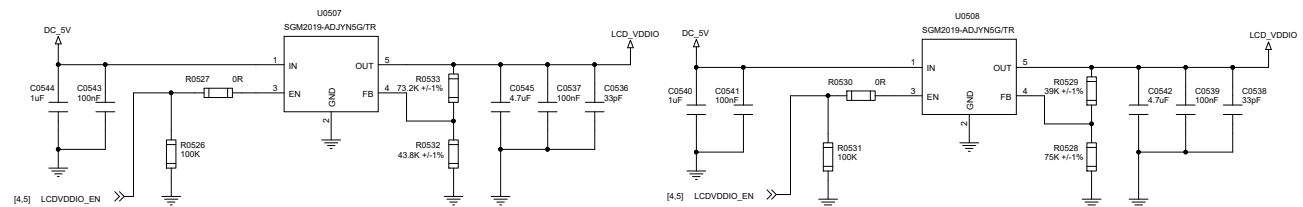

- NOTE:**
- When the LCM is used in the 3.2 V voltage domain, see the design of the U0507.
 - When the LCM is used in the 1.8 V voltage domain, see the design of the U0508.

$$\text{LCD_VDDIO} = 1.207 \times (1 + R0533 / R0532) \approx 3.2 \text{ V}$$

$$\text{LCD_VDDIO} = 1.207 \times (1 + R0529 / R0528) \approx 1.8 \text{ V}$$

LCM Analog Power Supply

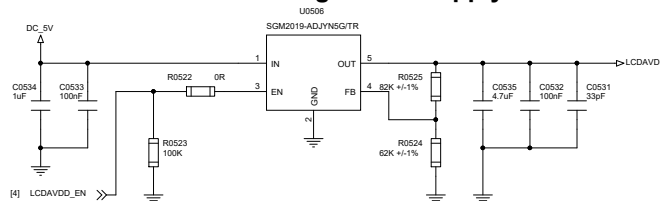

$$\text{LCDAVDD} = 1.207 \times (1 + R0525 / R0524) \approx 2.8 \text{ V}$$

Quectel Wireless Solutions

PROJECT	EG800G Series QuecOpen	VER	1.1
DRAWN BY	Phoenix FUJISIC MO	CHECKED BY	Anita HUANG
DATE	2024-12-09	SHEET	5 OF 19

Antenna Interface Design

Main Antenna Interface

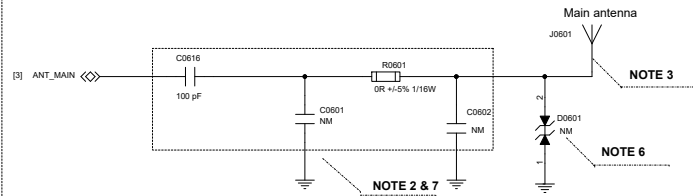

Wi-Fi Scan Antenna Interface

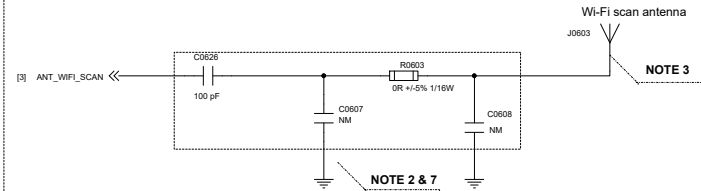

GNSS Antenna Interface

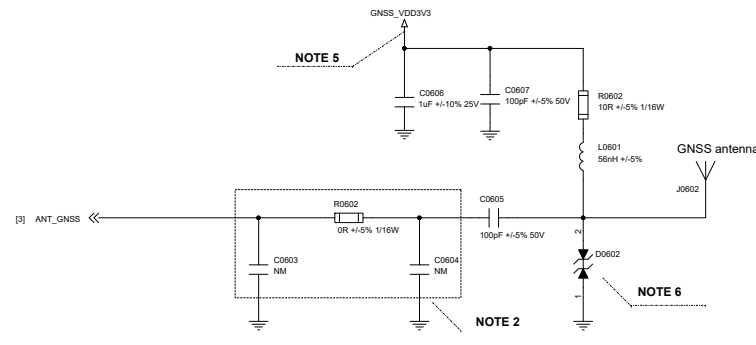

NOTE:

- The single-ended impedance of the RF antenna is 50 Ω.
- It is recommended to reserve a dual L-type circuit at these antenna interfaces.
- EG800G-CN supports Wi-Fi scan function, which shares the same antenna interface with main antenna. The two functions cannot be used simultaneously.
EG800G-EU/LA provides a dedicated Wi-Fi scan antenna interface (ANT_WIFI_SCAN). Wi-Fi scan supports receiving only.
- EG800G-CN supports GNSS function. EG800G-EU/LA does not support GNSS function.
- The active antenna uses an LDO for power supply, and GNSS_VDD3V3 circuit is not needed when using a passive antenna.
- It is recommended to reserve ESD protection components for the antenna interfaces and the junction capacitance should not exceed 0.05 pF.
- If there is DC power at the antenna ports, C0616 and C0626 must be used for DC-blocking to prevent short circuit to ground.
The capacitance value is recommended to be 100 pF, which can be adjusted according to actual requirements. If there is no DC power in the peripheral design, C0616 and C0626 should not be reserved.

Quectel Wireless Solutions			
PROJECT	EG800G Series QuecOpen		VER 1.1
DRAWN BY	Phiobe FUJIE-MO	CHECKED BY	Anita HUANG
DATE	2024-12-09	SHEET	6 OF 19

USIM Interface Design

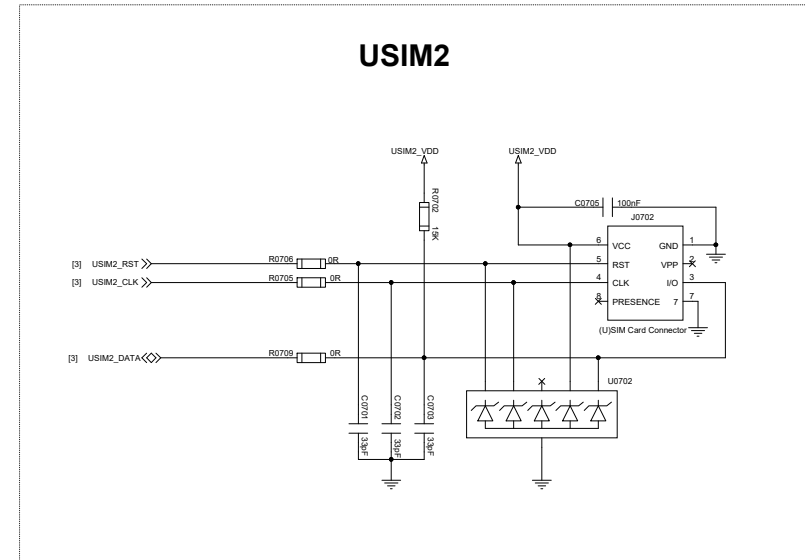
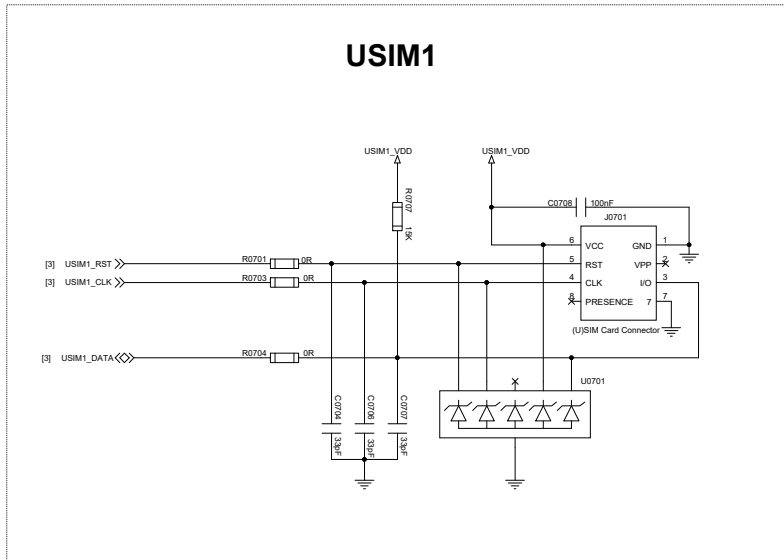

NOTE:

1. U0701 and U0702 are recommended to be used to offer good ESD protection, and the parasitic capacitance should not exceed 15 pF.
2. The pull-up resistors R0707 and R0702 can improve anti-jamming capability, and should be placed close to the USIM card connector.
3. R0701, R0703–R0706 and R0709 are used for debugging, and C0701–C0704, C0706 and C0707 are used for filtering out RF interference.
4. C0708 and C0705's capacitance should not exceed 1 μ F and they should be placed close to the USIM card connector.
5. The GND of the USIM card connector is recommended to be connected to the GND layer directly.
6. For more information about the layout of USIM interface, see the hardware design document of the module.
7. USIM_DET can be multiplexed from any GPIO pin of the module, which is at 1.8 V power domain.

UART Interface Design

UART Level-shifting Circuit - Transistor Solution



UART Level-shifting Circuit - IC Solution

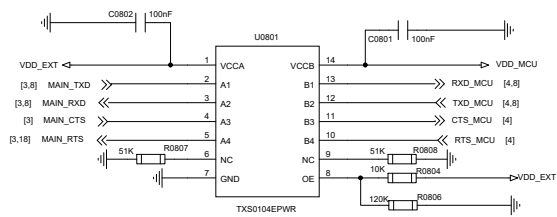

NOTE:

1. There are two level-shifting solutions: transistor solution and IC solution, and the latter one is recommended.
2. The power supply of TXS0104EPWR's VCCA should not exceed that of VCCB. For more information, see the datasheet of TXS0104EPWR.
3. The transistor solution is not suitable for applications with baud rates exceeding 460 kbps. The capacitors C0803 and C0804 of 1 nF can improve the signal quality.
4. MAIN_RTS transistor circuit is similar to that of the MAIN_RXD. MAIN_CTS transistor circuit is similar to that of the MAIN_TXD.

Quectel Wireless Solutions

PROJECT	EG800G Series QuecOpen		VER	1.1	
DRAWN BY	Phoenix FUJIE MO	CHECKED BY	Anita HUANG	SIZE	A2
DATE	2024-12-09	SHEET	8 OF 19		

Audio Codec Interface Design (Handset)

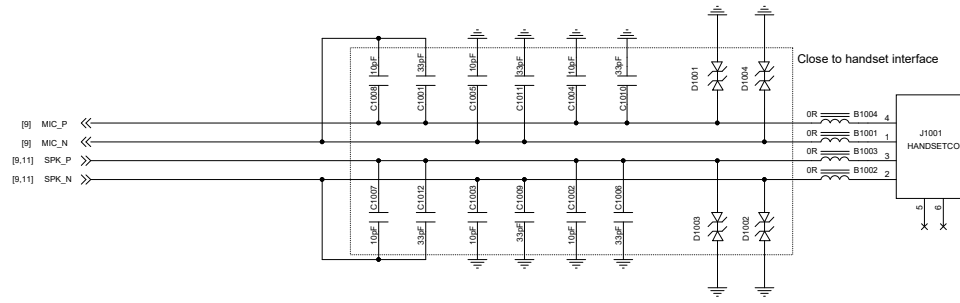

NOTE:

1. The codec analog output can drive handset. For larger power loads such as loudspeaker, add an audio power amplifier in the design.
2. In handset application, route the MIC and SPK signal traces as differential pairs.
3. Surround all MIC and SPK signal traces with ground on the same layer and with ground planes above and below to minimize noise interference, such as clock and DC-DC signals.

Quectel Wireless Solutions		
PROJECT	EG800G Series QuecOpen	VER 1.1
DRAWN BY	Checked FUJIE MO	CHECKED BY
		Ania HUANG
DATE	2024-12-09	SIZE A2
		SHEET 100F 19

Analog Audio Design (Audio Power Amplifier)

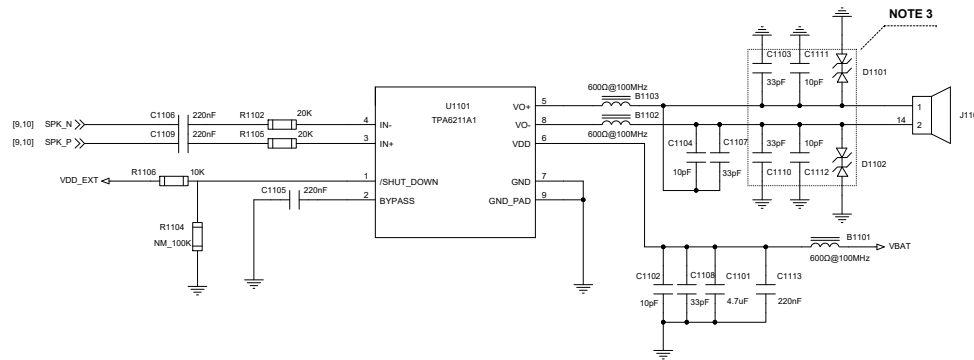

NOTE:

1. SPK_P and SPK_N channels are differential output channels intended for connecting to an external audio amplifier.
When the channels are turned on or off, it is possible for the module to emit a pop sound, which can be eliminated by controlling the enable pin of the audio PA. For details, contact Quectel Technical Support.
2. The audio power amplifier model in this design is for reference only. Select the amplifier with appropriate power according to actual needs.
3. When designing the layout, ensure that filter capacitors and ESD protection components are placed close to the loudspeaker to filter out interference and provide adequate protection.
4. The selection of ESD protection components should consider the output voltage range of the audio power amplifier. Ensure that the output voltage of the audio power amplifier remains within the maximum reverse working voltage range of ESD protection components under normal operating conditions. This precaution helps prevent damage to the ESD protection components.

Quectel Wireless Solutions		
PROJECT	EG800G Series QuecOpen	
	VER	1.1
DRAWN BY	CHECKED BY	SIZE
Phoenix FUJIE-MO	Ania HUANG	A2
DATE	2024-12-09	SHEET 11 OF 19

Camera Interface Design

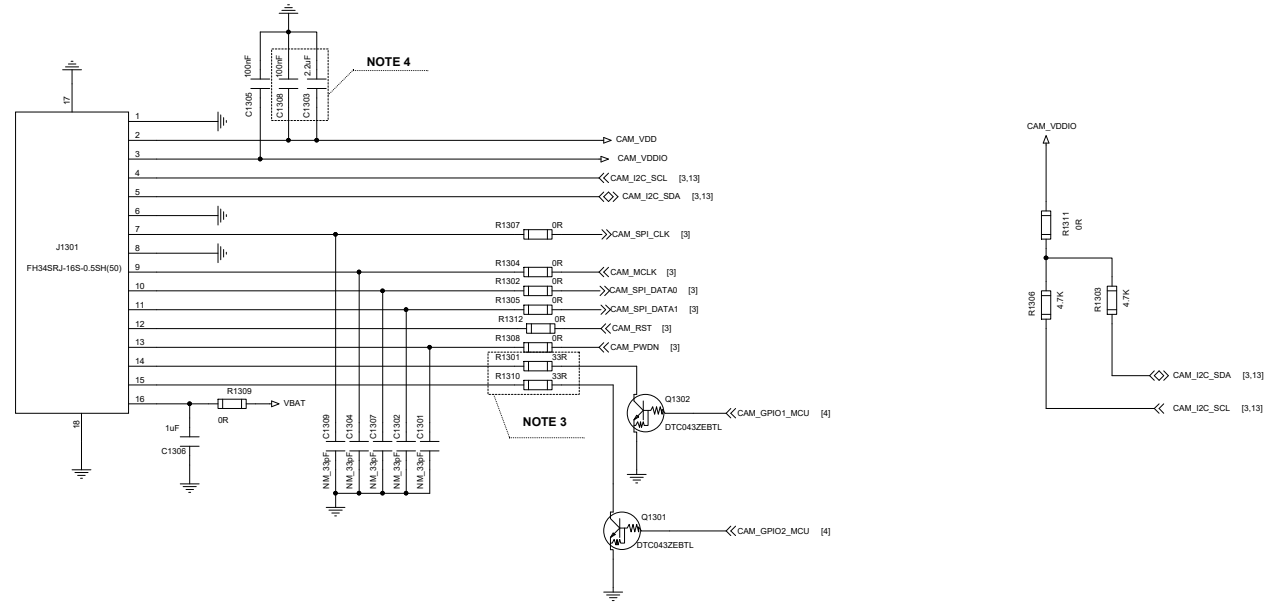

NOTE:

- By controlling the triode switching circuit, CAM_GPIO1_MCU controls the cathode of the positioning light of the camera, and CAM_GPIO2_MCU controls the cathode of the supplement light of the camera.
It is recommended to select default pull-down GPIO pins as the two control pins.
- The 33 pF capacitors of signal pins should be reserved, and be used according to the actual debugging situation.
- The values of current limiting resistors of positioning light and supplement light (R1301 and R1310) should be varied according to the required brightness.
- The capacitors of the CAM_VDD power supply should be connected to the GND layer directly, otherwise, power supply noise may lead to abnormalities such as white dots on the preview screen.
- It is recommended to design camera power supply by yourself.
- It is strongly recommended to use switch control for all power supplies, otherwise there may be leakage and power consumption increase.

Quectel Wireless Solutions

PROJECT	EG800G Series QuecOpen		VER	1.1	
DRAWN BY	Phoenix FUJIE-MO	CHECKED BY	Anita HUANG	SIZE	A2
DATE	2024-12-09	SHEET	130F	19	

Matrix Keypad Interface Design

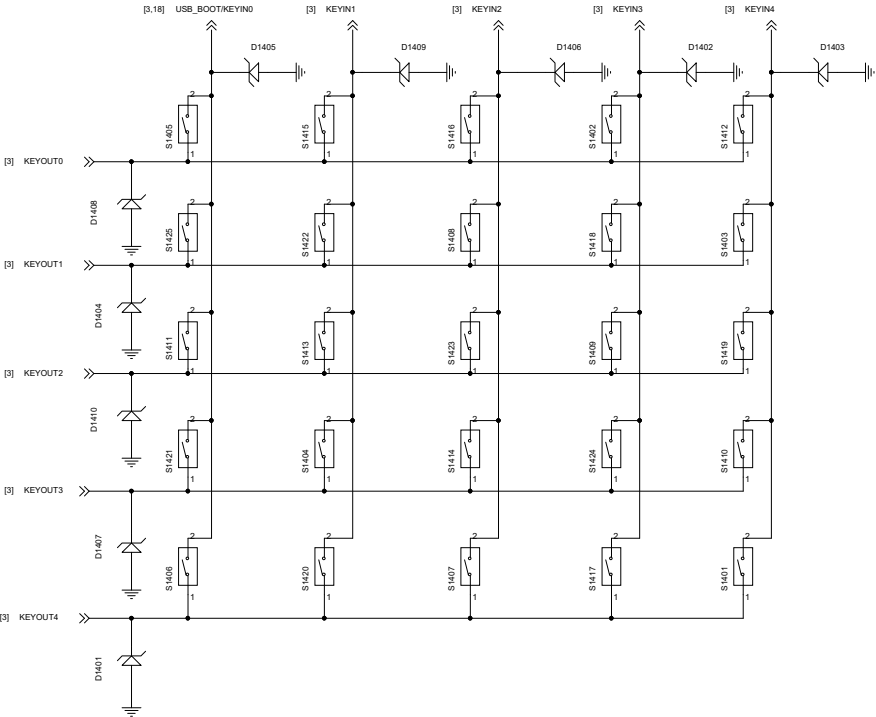

Quectel Wireless Solutions		
PROJECT	EG800G Series QuecOpen	
	VER 1.1	
DRAWN BY	CHECKED BY	SIZE
Phoebe FUJIE MO	Anita HUANG	A2
DATE	2024-12-09	SHEET 14 OF 19

External Flash Interface Design

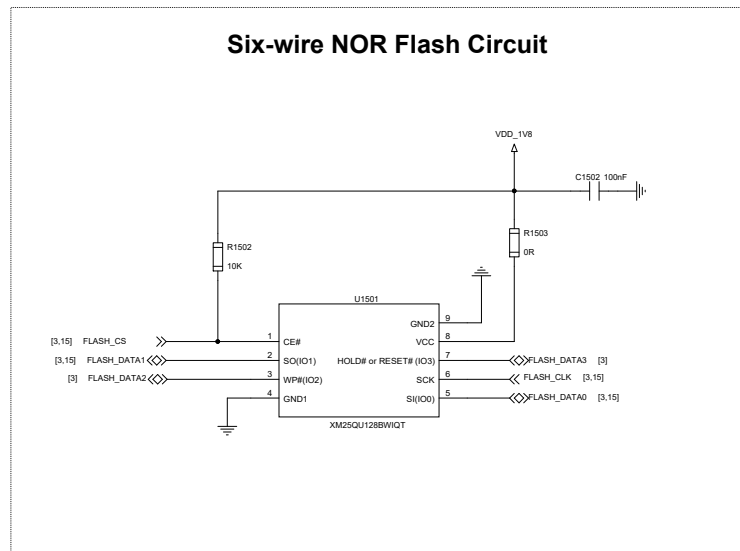
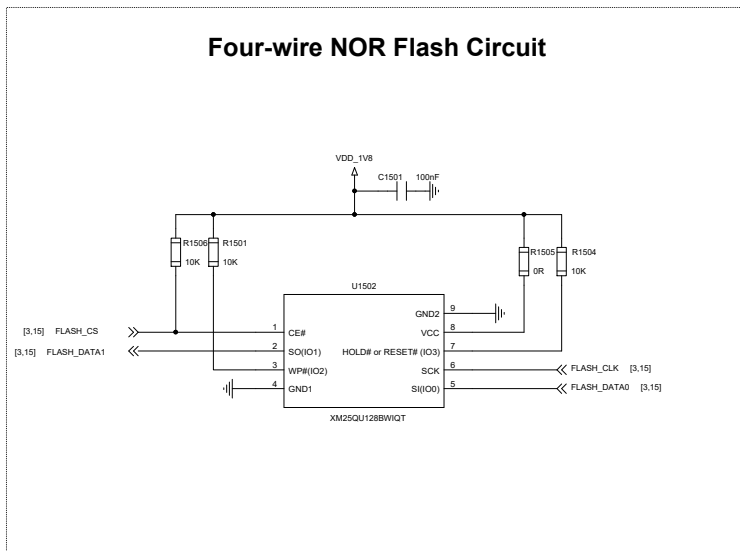

NOTE:

1. The filter capacitors C1501 and C1502 need to be placed close to the power supply pins of the flash chip.
2. For the four-wire NOR flash circuit, it is recommended to connect WP# and HOLD# pins with pull-up resistors to avoid damaging flash chips caused by abnormal levels, resulting in abnormal transmission or data loss.

Indicators

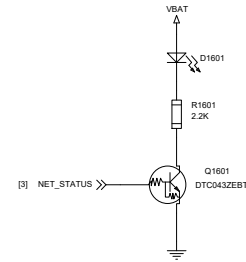
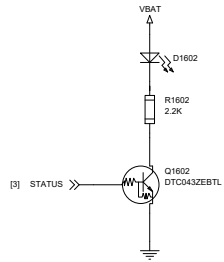

NOTE:

1. For more details about STATUS and NET_STATUS, see the hardware design document of the module.
2. If the low power consumption is required when your application is in sleep status, replace the power supplies (VBAT) of STATUS and NET_STATUS indication LEDs with the external controllable ones, which can be turned off to reduce the power consumption during module sleep status.

Quectel Wireless Solutions		
PROJECT	EG800G Series QuecOpen	
VER	1.1	
DRAWN BY	CHECKED BY	SIZE
Phoenix FUJIE MO	Ania HUANG	A2
DATE	2024-12-09	SHEET 16 OF 19

SD Card Interface Design

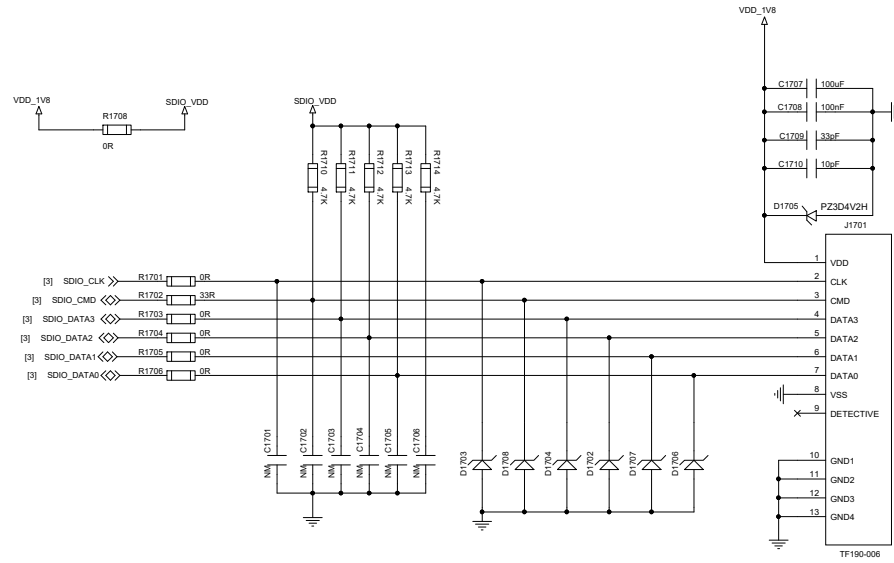

NOTE:

- Only 1.8 V SD card is supported.
- To avoid bus jitter, it is recommended to add pull-up resistors R1710–R1714 to the SDIO signal traces. The recommended value is 4.7 k Ω .
The pull-up power supply must select the SDIO_VDD.
- To improve signal quality, it is recommended to add resistors R1701–R1706 in series between the module and the SD card connector.
The bypass capacitors C1701–C1706 are reserved and not mounted by default.
- It is recommended to add ESD protection components near the pins of SD card connector. The parasitic capacitance of ESD protection components should be less than 15 pF.
- Keep SDIO signals far away from other sensitive circuits/signals such as RF circuits, analog signals, as well as noisy signals such as clock and DC-DC signals.
- Route SDIO signals with 50 Ω \pm 10 % impedance. It is important to route SDIO signals surrounded with ground on the same layer and with ground planes above and below, and the total trace length should be less than 50 mm.
- It is recommended to keep the traces among SDIO_CLK and SDIO_DATA[0:3]/SDIO_CMD with equal length (the difference among them is less than 1 mm).
- Make sure the adjacent trace spacing is twice the trace width and the bus capacitance is less than 15 pF.

Quectel Wireless Solutions			
PROJECT	EG800G Series QuecOpen		VER
			1.1
DRAWN BY	Checked FUJIE MO	CHECKED BY	Ania HUANG
			SIZE
			A2
DATE	2024-12-09	SHEET	17 OF 19

Test Points

USB Interface Test Points

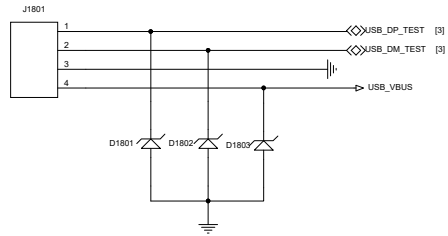

NOTE:

1. Test points must be reserved for USB interface.
2. The module can upgrade firmware and debug the software over USB interface.
The parasitic capacitance of the ESD protection components on USB data traces should not exceed 2 pF.

Forced Download Interface Test Point

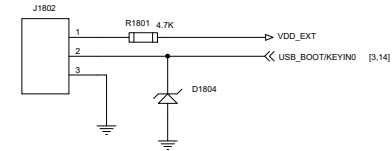

NOTE:

1. It is recommended to reserve a test point for forced download interface.
2. Pull down the USB_BOOT/KEYIN0 to GND before the module starts up, and the module will enter the forced download mode when it is turned on. In this mode, the module supports firmware upgrading over USB interface.

Debug UART Test Points

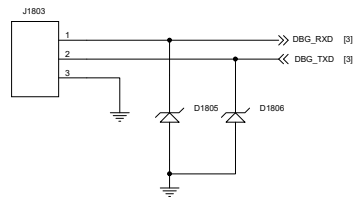

NOTE:

1. Test points must be reserved for DBG_TXD and DBG_RXD to capture AP logs.
2. The debug UART supports 1.8 V power domain, and a level-shifting circuit should be used if the power domain of your application is 3.3 V. For details, see the sheet "UART Interface Design".
3. The debug UART only supports the baud rate of 2000000 bps.

MAIN_RTS Test Point

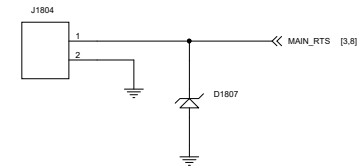

NOTE:

1. A test point must be reserved for MAIN_RTS to capture CP logs.
2. MAIN_RTS supports 1.8 V power domain, and a level-shifting circuit should be used if the power domain of your application is 3.3 V. For details, see the sheet "UART Interface Design".
3. When capturing CP logs, set the baud rate to 8000000 bps.

Quectel Wireless Solutions

PROJECT		EG800G Series QuecOpen		VER		1.1	
DRAWN BY		Phoebe FUJIEIC MO		CHECKED BY		Anita HUANG	
DATE		2024-12-09		SHEET		18 OF 19	

PWM Design

RC-filter Circuit

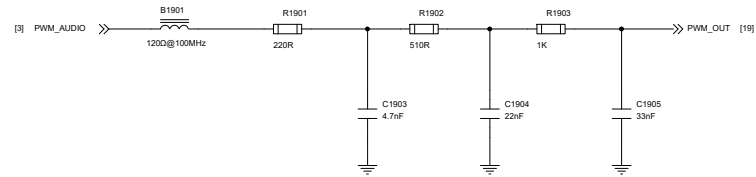

NOTE:

1. It is recommended to reserve a third-order RC low-pass filter circuit, and the capacitance and resistance need to be adjusted according to the audio effect and the matched audio PA. This circuit is for reference only.
2. You can use low-pass filters such as first-order, second-order or third-order RC or LC according to the needs.

PA Design

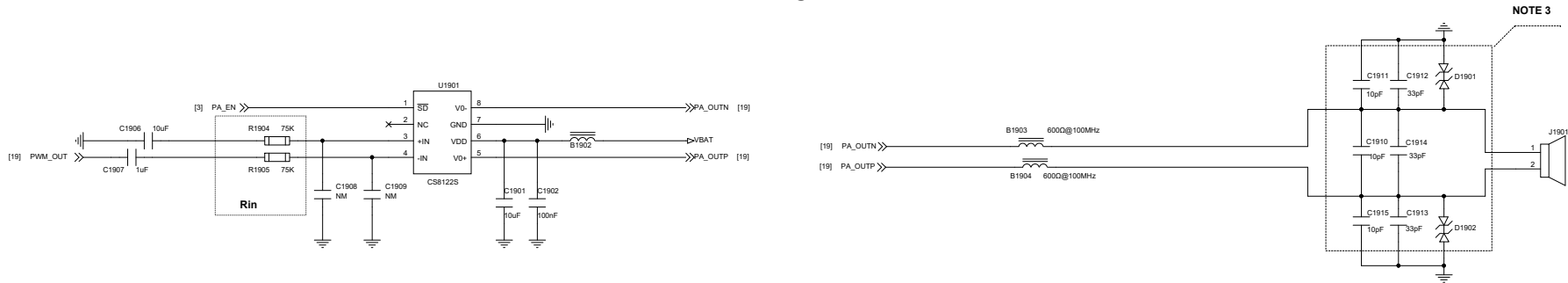

NOTE:

1. Rin is the input resistance. By adjusting the resistance of the input resistor, the amplification factor of the audio PA can be set.
The calculation formula is: $\text{Gain} = 2 \times 150 \text{ k}\Omega / R_{in}$.
2. Choose the audio power amplifier with appropriate power according to the actual needs.
3. The selection of ESD protection components should consider the output voltage range of the audio power amplifier. Ensure that the output voltage of the amplifier remains within the maximum reverse working voltage range of the selected ESD protection components under normal operating conditions. This precaution helps prevent damage to the ESD protection components.

Quectel Wireless Solutions

PROJECT	EG800G Series QuecOpen	VER	1.1
DRAWN BY	Phoenix FUJIE-MO	CHECKED BY	Anita HUANG
DATE	2024-12-09	SIZE	A2
		SHEET	19 OF 19